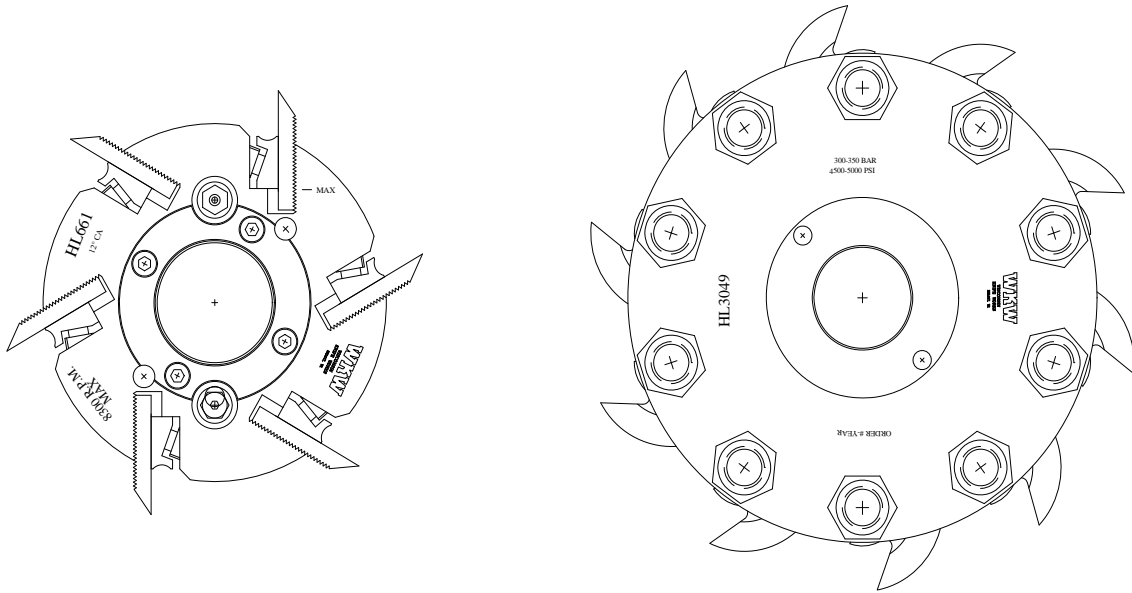

STANDARD HYDRO HEADS™

Use lock rings on all hydro loc tooling.

Each hydro loc head is equipped with a filler nipple and a grease release valve on each end of the head. This allows the head to be used on any spindle (top-bottom-left-or right). The heads are very easy to attach to the spindle by following the steps listed below.

Note: To insure an accurate and proper set-up, parts should be free of dirt, pitch, etc.

1. After head is properly assembled, place head at the desired position on the machine spindle.
2. Connect the grease gun to the filler nipple (zerk fitting) on the head and open the release valve using a 3mm wrench.
3. Loosen the screw on the gauge block, pump until grease oozes out of the release valve. This ensures that air pockets inside the grease chamber are eliminated.
4. Using the 3mm allen wrench, tighten the release valve on the head. Pressurize to a minimum of 300 bar (4,500 p.s.i.).
5. Install lock ring.
6. It is a good practice to recheck the pressure each morning or after the machine has been idle for any length of time.

HEAD MAINTENANCE

HYDRO-LOC™ & QUICK-LOC™ HEAD MAINTENANCE

The arbor or spindle must be free from runout and wear for your cutterhead to properly lock on the arbor and to produce the optimum finish, the arbor size should be no more than .0005 less than the nominal size. Runout in your spindle will also prevent your cutterhead from performing properly.

Hydro-loc™ and Quick-Loc™ heads rely on grease pressure and are equipped with a release valve, or set screw in the case of a Quick-Loc™ head. The following steps should be observed. When using Hydro-loc™ or Quick-Loc™ heads, always use a locking collar to guard against unexpected pressure loss that could lead to damage of the arbor and/or the cutterhead.

Hydro-loc™ Heads

1. Place the head in the desired location on the spindle. Never pressurize a head when it is not on a spindle or when your spindle is .001 inch or more under the nominal diameter. Damage to the head could result.
2. Connect the grease gun to the filler nipple. Always use the WKW recommended grease gun. A regular grease gun will not pressurize the head to a high enough pressure.
3. Loosen the screw valve on the gauge block and pump until grease flows out the release valve. This will remove any air pockets inside the head.
4. Tighten the screw in the release valve on the head and pressurize to 300-350 bar (4350-5075 p.s.i.). Tighten the screw valve on the gauge block and loosen the grease release valve on the gun. Remove the grease gun.
5. If there is no pressure loss within two minute, install and tighten the lock ring. You may proceed if you have read and understand the information provided by the machine manufacturer. Never operate a Hydro-loc™ cutterhead without a lock ring.
6. Always be sure to check for any pressure loss each morning, after each shift change, or after the machine has been idle for more than eight hours.
7. If cleaning the head with a heated solution, always be sure that the pressure release fitting is left open to prevent sleeve damage.

Quick-Loc™ heads also rely on grease pressure and are equipped with one or two set screws. Only one screw needs to be used to pressurize and release the head. To lock the head into the arbor, the set screw should be tightened by hand until it bottoms out, using the allen wrench that is provided. Do not use a torque wrench or any device to add torque. Simple hand pressure is adequate. To remove the head from the arbor, merely loosen the screw one or two rotations or until the head loosens on the arbor. It is not necessary to remove the screw.

Re-charging Quick-Loc™ heads is recommended after every 100 hours of use. To re-charge the head, merely place it on an arbor, tighten the pressurizing screws until they bottom out, and re-charge to 300-350 bar (4350-5075 p.s.i.) with the grease gun. Do not over or under pressurize. Periodic checking of the pressure is recommended in this manner. Never pressurize when the head is not on a proper sized arbor.